

What is textured protein products?

Detail Introduction :

1 Brief introduction of textured protein products

Textured protein products is a new type of soybean product such as soybean protein isolate and soy tissue protein extracted from low-temperature soybean meal as raw material. Can be made by soyab chunks making machine



2 Introduce of Textured Soy Protein

Textured Soy Protein is also called vegetable protein meat. It is a variety of forms made by using soybean defatted protein powder as raw material, crushed, mixed with water, and specially processed in special extruder equipment--soya nuggets extruder. Lean meat, protein food with chewy feeling.



The so-called tissue protein refers to the denaturation of the protein after the soybean is processed for soyabean chunks making machine , and the protein molecules are rearranged and oriented to form a tissue structure with the same direction, and at the same time, the fibrous protein is formed after coagulation.

3 How to produce Textured Vegetable Protein Products

The follow chart of textured Vegetable Protein Products is:

Flour Mixer-Screw Hoister-Double Screw Extruder-Hoister-Oven-Cooling Conveyor-Packing Machine
 Shandong Loyal industrial has 18 years experience on the soya bari machine. Welcome to contact us.

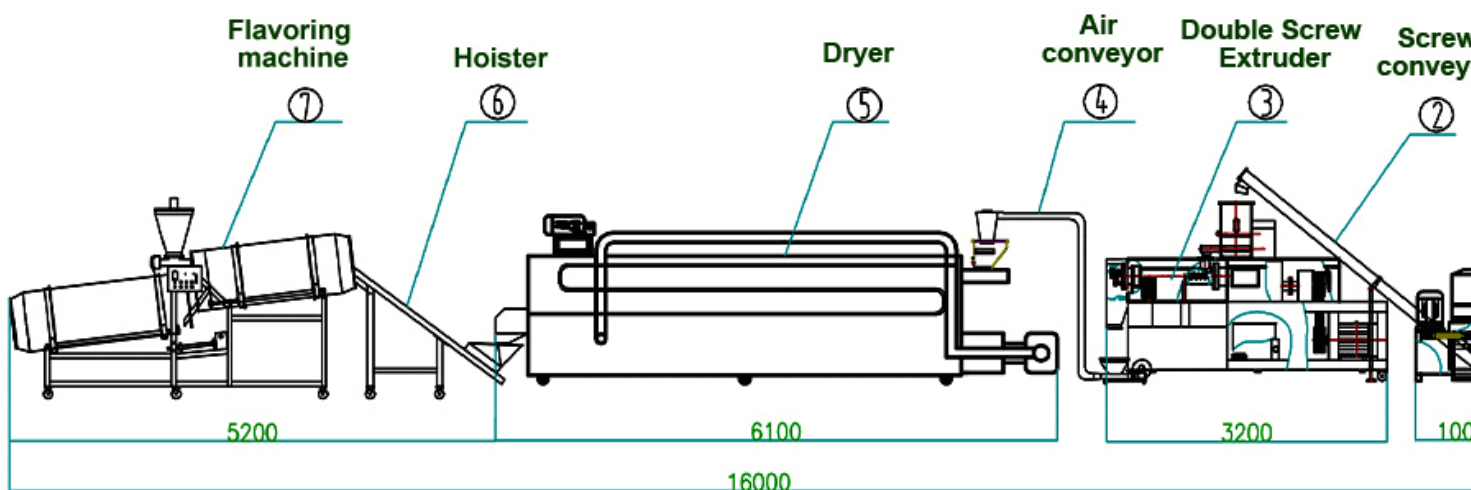

1. Flour mixing machine: mix low-temperature soybean meal, protein isolate and other mixed additives in a certain proportion of water fully and evenly.
2. Feeder: convey the mixed raw materials to the feeding hopper of the extruder.
3. Soya nuggets extruder: After the raw material enters the extrusion system from the feeder, pellets are produced, and products of different sizes can be produced by changing the mold.
4. Lifter: transport the product to the oven.
5. Multi-layer oven: remove—fix the moisture and extend the shelf life.
6. Cooling conveyor: cooling to room temperature for easy packaging.

4 parameters and output of the soybean protein production line

Model	LY-65	LY-70	LY80
Installed Power	90kw	110kw	150kw
Power Consumption	70kw	90kw	130kw
Capacity	100-150kg/h	150-200kg/h	300-350kg/hr
Dimension	19x2x3.5m	32x2.5x3.5m	38*4.5*6.5m

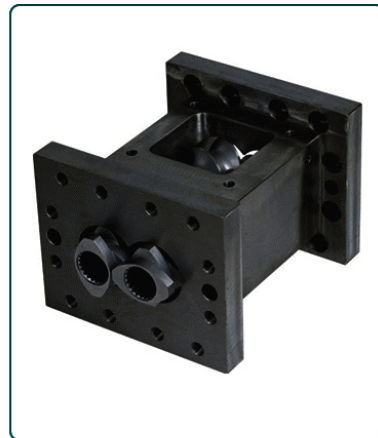
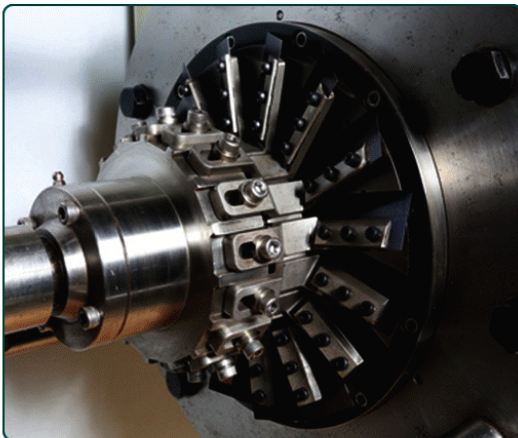
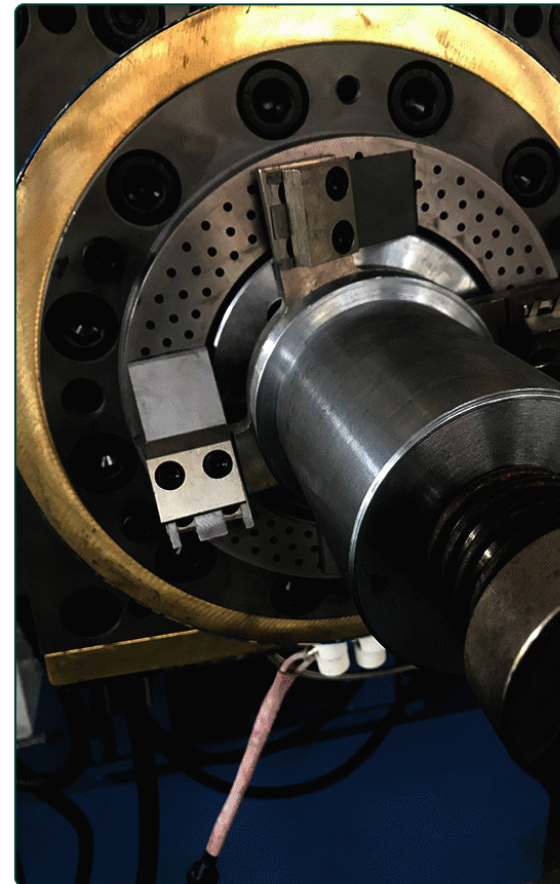

5 Structural characteristics of textured protein products

- (1) The structure of the textured protein products is granular, with multiple fleshy tissues and excellent water retention and chewing feeling.
- (2) It has been processed under short-term high temperature, high moisture and pressure conditions.

eliminate many harmful substances contained in soybeans, such as trypsin, urease, saponin, hema etc., and improve protein Absorption and digestion capacity. After heat treatment, the nutritional value of starch in soybeans has been significantly improved.

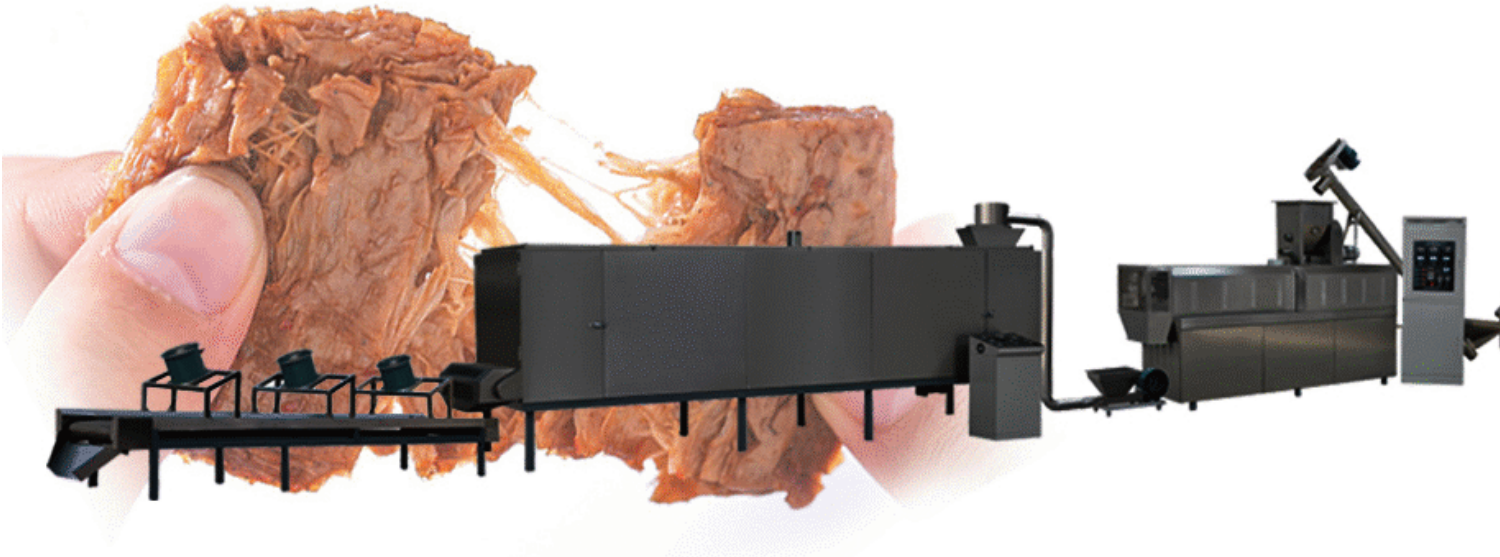

6 Characteristics of textured protein products

(1) The use of textured protein products can not only increase the protein content of the product, reduce the content of animal fat and cholesterol, prevent the tissue from being damaged by high temperature heat and mechanical action, and lose the touch of the meat, but also can reduce the cost of the product. .

(2) The application of soybean tissue protein in meat products is mainly considering their economy and nutrition, followed by functionality. Economy mainly refers to the lower price of soybean tissue protein products, which can be used to replace a part of meat. It can reduce the cost of the product; nutritionally, that after the soy protein is added to the meat product, it can increase the protein content of the product, reduce the content of animal fat and cholesterol, and adapt to the modern nutritional needs.

7 Sample of the soybean protein production line

