

# The Ultimate Energy Bar Machine Guide to 2024

Introducción detallada :

Introduction to Energy Bar Machines

Types of Energy Bar Machines

Key Features to Look for in Energy Bar Machines

Benefits of Using Energy Bar Machines

How Energy Bar Machines Work

Choosing the Right Energy Bar Machine for Your Production Needs

Maintenance Tips for Energy Bar Machines

Energy Efficiency Considerations in Energy Bar Machines

Trends and Innovations in Energy Bar Machine Technology

Common Challenges and Solutions in Using Energy Bar Machines

## Introduction to Energy Bar Machines

[Energy bar machines](#) represent the pinnacle of efficiency and innovation in the realm of industrial food processing equipment. Designed specifically for producing energy bars, these machines utilize cutting-edge technology to streamline production while ensuring consistency and quality. They are indispensable in large-scale manufacturing facilities where demand for nutritious and convenient energy snacks is high.

Energy bar machines typically consist of several key components: a mixing chamber where ingredients are blended to form the bar base, a molding unit that shapes the bars into desired sizes and shapes, and a cooling conveyor to solidify the bars before packaging. Each component is meticulously engineered to optimize the production process, from raw ingredient input to final product packaging. These machines are not only about automation but also precision. They allow manufacturers to maintain stringent quality control measures, ensuring that every energy bar meets nutritional standards and taste expectations. By automating repetitive tasks and minimizing human intervention, [energy bar machines](#) enhance production efficiency while reducing labor costs, making them indispensable assets in today's competitive food industry.



## Types of Energy Bar Machines

Energy bar machines come in several types, each tailored to different production needs and capacities. Below is a detailed table outlining the key types of energy bar machines:

Type of Energy Bar Machine	Description
Automated Mixing Systems	These machines automate the blending of ingredients, ensuring precise ratios and thorough mixing for consistent product quality. They often include features like temperature control and ingredient dispensing.
Extrusion Machines	Extrusion machines shape and cut energy bar mixtures into desired forms. They utilize high-pressure systems to mold and finalize the bars before packaging.
Cooling and Drying Systems	Essential for post-production, these systems rapidly cool and dry energy bars to stabilize texture and prolong shelf life. They employ controlled airflow and temperature settings to achieve optimal results.
Packaging Lines	Integrated packaging lines ensure efficient and hygienic packaging of energy bars. They encompass processes such as bar alignment, wrapping, and labeling, enhancing production line efficiency.

Each type of energy bar machine plays a crucial role in the overall manufacturing process, contributing to the seamless production of high-quality energy bars that meet consumer expectations for taste, nutrition, and consistency.



## Key Features to Look for in Energy Bar Machines

When investing in an energy bar machine, several key features distinguish top-tier models:

**Production Capacity:** Modern energy bar machines are designed to handle varying production capacities, from small-scale operations to large-scale industrial needs. Look for machines that align with your production volume requirements.

**Versatility in Recipe Handling:** The ability to handle a wide range of recipes is crucial. Advanced machines offer flexibility in processing different ingredients and textures, ensuring you can cater to diverse consumer preferences.

**Automation and Efficiency:** Efficiency is paramount in industrial settings. Look for machines equipped with automated processes for mixing, molding, and cutting energy bars. This reduces costs and enhances overall productivity.

**Quality Control Mechanisms:** Precision in product dimensions and consistency in texture are maintained through robust quality control features. This includes sensors for thickness control, temperature monitoring, and automated rejection of faulty products.

**Ease of Cleaning and Maintenance:** Hygiene standards must be upheld in food production. Machines with easy-to-clean surfaces, removable parts, and straightforward maintenance routines minimize downtime and ensure consistent quality.

downtime and ensure compliance with food safety regulations.

**Energy Efficiency:** Sustainable practices are increasingly valued. Energy bar machines that optimize energy consumption without compromising output quality contribute to environmental stewardship and operational cost savings.



## Benefits of Using Energy Bar Machines

**Enhanced Production Efficiency:** Energy bar machines streamline production processes, reducing manual labor and operational time. Automated mixing, molding, and cutting significantly boost output while maintaining product consistency.

**Consistent Product Quality:** Precision engineering in energy bar machines ensures uniformity in product dimensions, texture, and taste. This consistency is vital for building consumer trust and loyalty.

**Cost Savings:** By automating repetitive tasks and minimizing waste through precise ingredient handling, energy bar machines help lower production costs over time. Reduced labor costs and optimized energy consumption contribute to improved profitability.

**Adaptability to Market Demands:** Flexibility in recipe handling enables manufacturers to quickly respond to changing consumer preferences. Whether producing gluten-free, vegan, or protein-rich energy bars, versatile machines accommodate diverse market demands.

In conclusion, investing in a quality energy bar machine not only enhances operational efficiency and product consistency but also positions manufacturers to capitalize on evolving market trends. By prioritizing features like production capacity, automation, and versatility, businesses can achieve sustainable growth in the competitive food processing industry of 2024.



## How Energy Bar Machines Work

Energy bar machines are intricate pieces of equipment designed to streamline the production of energy bars. These machines operate on a series of precise mechanisms that ensure efficiency and consistency in every batch produced.

At the core of an energy bar machine is its ability to mix ingredients thoroughly. This is achieved through a combination of high-speed mixing blades and automated ingredient dispensers. The components work in tandem to blend various ingredients such as nuts, oats, protein powders, and sweeteners into a uniform mixture.

Once the ingredients are mixed, the machine processes the mixture into a consistent dough or batter. This stage involves shaping the dough into the desired form, whether it's a slab for cutting into bars or a molded shape for specialty bars like protein bars or granola bars.

Temperature control is critical during the processing phase to ensure that the ingredients bind together without compromising their nutritional integrity. Energy bar machines employ advanced heating and cooling systems to maintain optimal temperatures throughout the production cycle.

Finally, the formed bars undergo quality control checks before being packaged. These checks include weight verification, visual inspection for consistency, and sometimes even nutritional analysis to ensure compliance with regulatory standards.



## Choosing the Right Energy Bar Machine for Your Production Needs

Selecting the right energy bar machine hinges on several key factors that cater to your specific production requirements. Understanding these factors can help streamline your decision-making process and optimize your production efficiency.

Firstly, production capacity plays a pivotal role in selecting an energy bar machine. Machines vary widely in terms of their output capacity, ranging from small-scale units suitable for boutique operations to large-scale industrial machines capable of high-volume production.

Secondly, consider the versatility of the machine. Some energy bar machines are designed for specific types of bars, such as protein bars or granola bars, while others offer flexibility to produce a variety of bar types. Assessing your product lineup and future expansion plans can guide you towards a machine that aligns with your production goals.

Thirdly, efficiency and automation are crucial considerations. Modern energy bar machines incorporate automation features that streamline production processes, reduce labor costs, and minimize human error. Look for machines equipped with intuitive controls, automated cleaning systems, and preventive maintenance capabilities to enhance operational efficiency.

Lastly, factor in budget and return on investment (ROI). Energy bar machines represent a significant investment, so it's essential to weigh upfront costs against long-term benefits. Evaluate not only purchase price but also ongoing maintenance expenses, energy consumption, and potential revenue growth facilitated by increased production capacity.



## Maintenance Tips for Energy Bar Machines

Maintaining an Energy Bar Machine is crucial for ensuring optimal performance and longevity. Regular maintenance helps in preventing unexpected breakdowns and reduces operational costs. One of the essential maintenance tips is to keep the machine clean. After each production cycle, thoroughly clean all parts of the Energy Bar Machine that come into contact with food material, which includes the mixing chambers, extruders, and conveyors. Using food-safe cleaning agents will prevent contamination and ensure compliance with hygiene standards.

Another important maintenance aspect is lubrication. Proper lubrication of moving parts reduces friction and wear, which is vital for the smooth operation of the Energy Bar Machine. Check the manufacturer's guidelines for the recommended lubrication schedule and use the specified lubricant. Over-lubrication can be just as harmful as under-lubrication, so it's crucial to follow the guidelines closely to maintain the efficiency of the machine.

Regular inspection of machine components is also necessary. This includes checking belts, gears, and seals for signs of wear or damage. Replacing worn-out parts before they fail can prevent more extensive damage to the Energy Bar Machine and avoid costly downtime. Implementing a routine inspection

schedule can help identify potential issues early and address them promptly.

Lastly, keeping detailed maintenance records is beneficial. Documenting all maintenance activities, including cleaning, lubrication, and parts replacement, helps track the machine's condition over time. This information can be invaluable for troubleshooting issues and making informed decisions about future maintenance needs. Well-maintained Energy Bar Machines not only operate more efficiently but also produce higher-quality energy bars consistently.

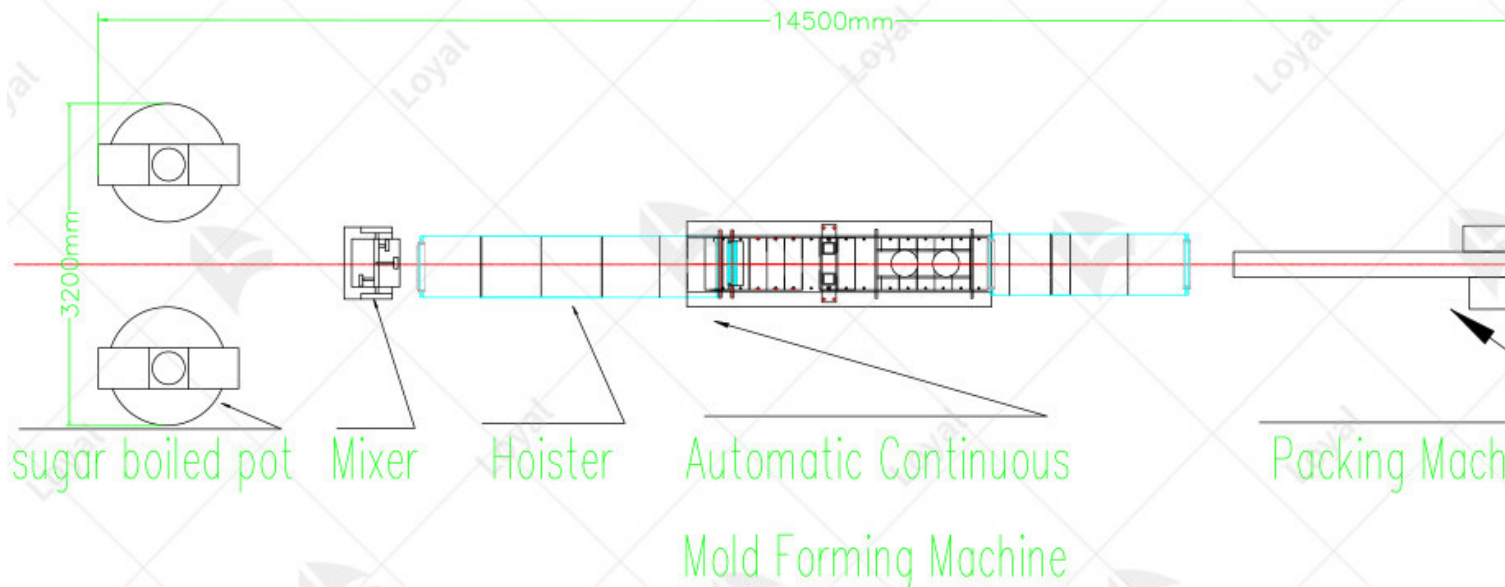

## Energy Efficiency Considerations in Energy Bar Machines

Energy efficiency is a key factor when operating an Energy Bar Machine. Efficient machines reduce operational costs and have a lower environmental impact. One way to enhance energy efficiency is by optimizing the machine's settings for each batch of energy bars. Adjusting parameters such as temperature, mixing speed, and extrusion pressure to the specific requirements of the recipe can help minimize energy consumption while maintaining product quality.

Another consideration is the insulation of heating elements. Properly insulated heating elements reduce heat loss, ensuring that more energy is used for processing rather than wasted. This is particularly important in machines that operate at high temperatures for extended periods. Regularly inspecting and maintaining insulation can significantly improve the energy efficiency of an Energy Bar Machine.

The use of energy-efficient motors and drives also plays a crucial role. Upgrading to high-efficiency motors can reduce energy consumption without compromising performance. Variable frequency drives (VFDs) allow for precise control of motor speed, which can further enhance energy savings. By adjusting the motor speed to match the specific needs of the production process, VFDs prevent unnecessary energy use and improve overall efficiency.

Finally, implementing energy monitoring systems can help track energy usage in real time. These systems provide valuable data that can be used to identify areas where energy is being wasted and opportunities for improvement. By analyzing this data, operators can make informed decisions about adjustments to the Energy Bar Machine's operation, leading to more efficient energy use. Investing in energy efficiency not only reduces costs but also contributes to a more sustainable production process.



## Trends and Innovations in Energy Bar Machine Technology

In 2024, the energy bar machine industry is witnessing significant advancements. Manufacturers are focusing on automation to enhance efficiency and consistency. Energy bar machines now feature sophisticated control systems that ensure precise ingredient mixing and uniform bar shaping. This technological innovation reduces human error and increases production speed, making the manufacturing process more reliable and cost-effective.

Another trend is the integration of IoT (Internet of Things) technology in energy bar machines. IoT-enabled machines allow for real-time monitoring and data analysis. This connectivity provides manufacturers with insights into machine performance, helping to predict maintenance needs and optimize production schedules. The ability to remotely access and control energy bar machines enhances operational flexibility and reduces downtime.

Sustainability is also a key focus in energy bar machine development. New machines are designed to be energy-efficient, reducing their environmental footprint. Manufacturers are using recyclable materials and incorporating energy-saving features to minimize waste. This shift towards sustainable practices not only benefits the environment but also aligns with the growing consumer demand for eco-friendly products.

Lastly, customization capabilities have significantly improved. Modern energy bar machines can be easily adjusted to produce bars of various sizes, shapes, and ingredient compositions. This flexibility allows manufacturers to cater to diverse consumer preferences and dietary requirements, such as

gluten-free or high-protein bars, without needing multiple machines.



## Common Challenges and Solutions in Using Energy Bar Machines

Despite advancements, manufacturers still face challenges when using energy bar machines. One common issue is ingredient consistency. Variations in ingredient quality can affect the texture and taste of the final product. To address this, manufacturers are implementing more rigorous quality control measures and sourcing high-quality, consistent ingredients.

Another challenge is machine maintenance. Energy bar machines, like all industrial equipment, require regular maintenance to function optimally. Preventive maintenance programs, guided by data analytics, are becoming more prevalent. These programs help identify potential issues before they cause machine downtime, ensuring continuous production and extending the lifespan of the equipment.

Operational efficiency is also a concern, particularly for small-scale producers. The initial investment in high-tech energy bar machines can be substantial. To mitigate this, manufacturers are offering leasing options and modular machines that can be upgraded as production demands grow. This approach allows smaller producers to scale their operations without significant upfront costs.

Lastly, meeting regulatory standards is crucial but challenging. Energy bar production must comply with strict food safety regulations. Modern energy bar machines are designed with easy-to-clean components and built-in safety features to meet these standards. Manufacturers are also investing in staff training to ensure proper machine operation and adherence to hygiene protocols.